

# SG128128A ( 128 DOTS X 128 DOTS )

## ! FEATURES

- " BUILT-IN CONTROLLER T6963C OR EQUIVALENT)
- " +5 V POWER SUPPLY
- " 1/128 DUTY CYCLE
- " 8-BIT PARALLEL INTERFACE

## ! MECHANICAL DATA

ITEM	DIMENSIONS	UNIT
Module Size ( W x H x T )	88.0 x 88.0 x 16.3	mm
Viewing Area ( W x H )	69.0 x 69.0	mm
Active Area ( W x H )	63.96 x 63.96	mm
Dot Size ( W x H )	0.46 x 0.46	mm
Dot Pitch ( W x H )	0.50 x 0.50	mm

## ! INTERFACE PIN CONNECTIONS

NO.	SYMBOL	LEVEL	FUNCTION
1	Vss	0V	Power Supply Ground
2	VDD	5V	Power Supply Voltage
3	Vo	-	Contrast Adjustment Voltage
4	C/D	H/L	H : Instruction Code, L : Data Code
5	/RD	L	Read Signal
6	/WR	L	Write Singal
7-14	DB0-DB7	H/L	Data Bus Line
15	/CE	L	Enable Signal
16	/RST	L	Reset Signal
17	VEE	-	Power Supply Voltage For LCD
18	MD2	H/L	H : 32/L : 40 Select of Columns
19	FS1	H/L	H : 6*8 , L : 8*8 Select Of Columns
20	NC	-	No Connection

## ! ABSOLUTE MAXIMUM RATINGS

ITEM	SYMBOL	MIN.	TYP.	MAX.	UNIT
Supply Voltage For Logic	VDD-Vss	0	-	7	V
Supply Voltage For LCD Drive	VDD-Vo	0	-	28	V
Input Voltage	Vi	Vss	-	VDD	V

## ! ELECTRICAL CHARACTERISTICS

ITEM	SYMBOL	CONDITION	MIN.	TYP.	MAX.	UNIT	
Supply Voltage For Logic	VDD-Vss	-	4.5	5	5.5	V	
Supply Voltage For LCD	VDD-Vo	VDD=5V Ta=25#	17.2	18.5	19.6	V	
Supply Current	IDD	VDD=5V	-	16	25	mA	
Input Voltage	"HIGH" Level	V <sub>IH</sub>	-	2.2	-	VDD	V
	"LOW" Level	V <sub>IL</sub>	-	-	-	0.6	V
Output Voltage	"HIGH" Level	V <sub>OH</sub>	-	2.4	-	-	V
	"LOW" Level	V <sub>OL</sub>	-	-	-	0.4	V

## ! EXTERNAL DIMENSIONS

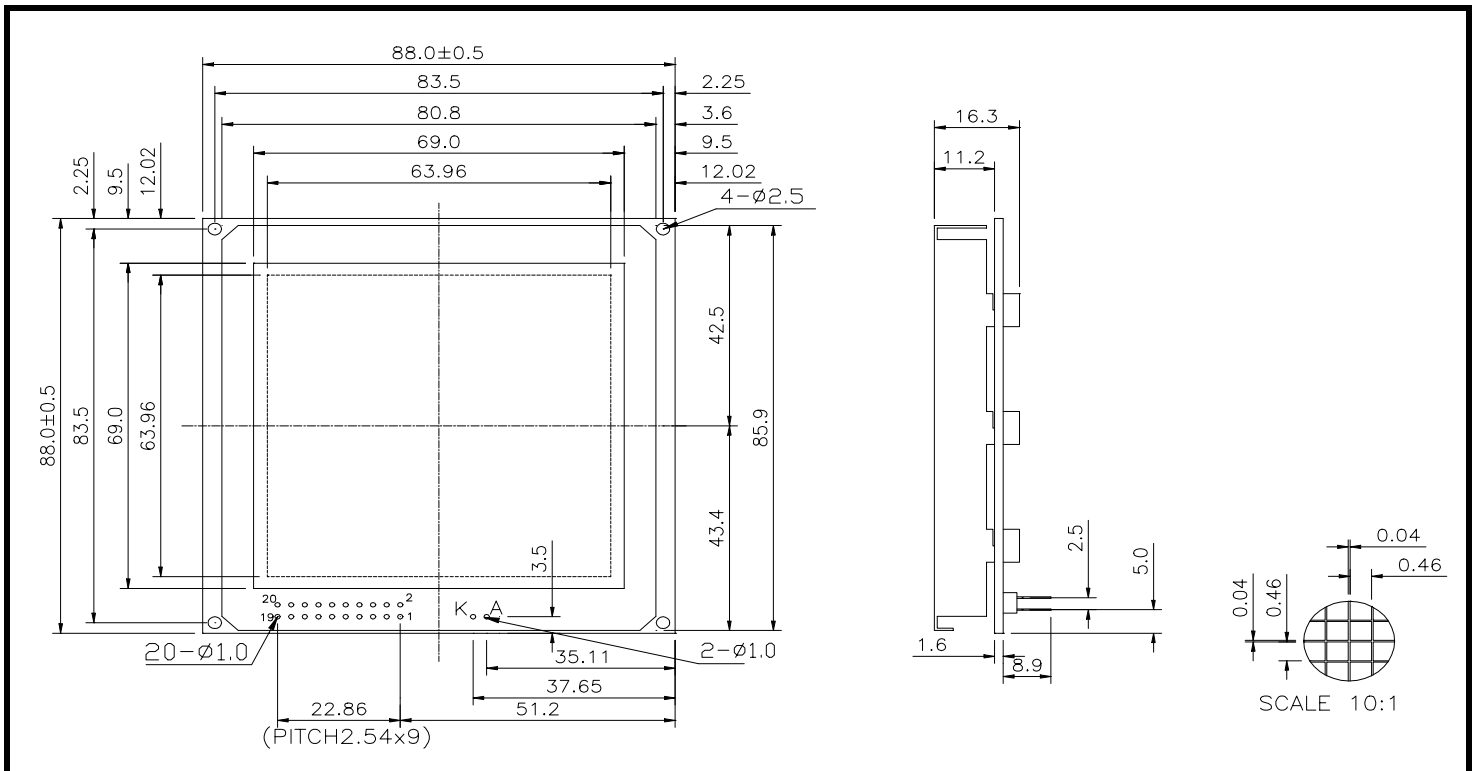

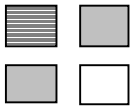

# SG128128A ( 128 DOTS X 128 DOTS )

## ■ TIMING CHARACTERISTICS

ITEM	SYMBOL	MIN.	MAX.	UNIT.
C/D Setup Time	$t_{CDS}$	100	-	ns
C/D Hold Time	$t_{CDH}$	10	-	ns
CE, RD,WR Pulse Width	$t_{CE}, t_{RD}, t_{WR}$	80	-	ns
Data Setup Time	$t_{DS}$	80	-	ns
Data Hold Time	$t_{DH}$	40	-	ns
Access Time	$t_{ACC}$	-	150	ns
Output Hold Time	$t_{OH}$	10	50	ns

Bus Timing

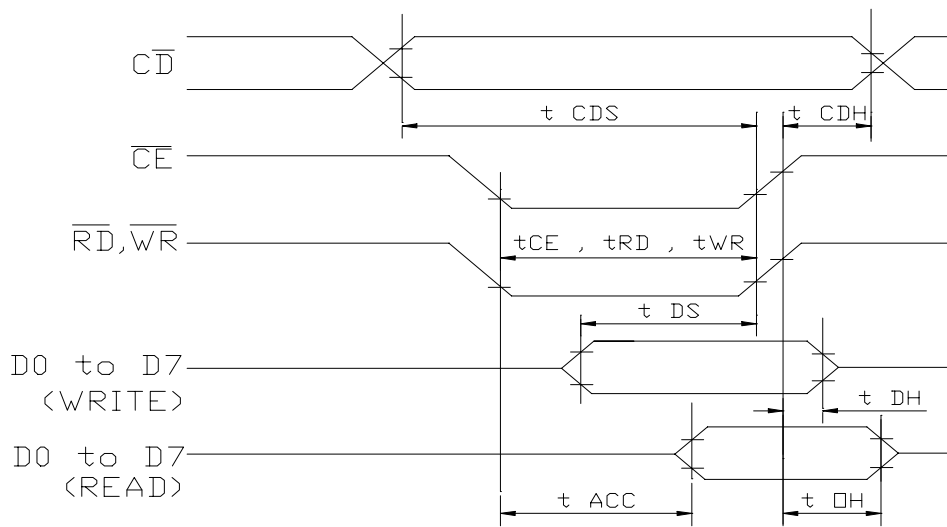

## ■ BLOCK DIAGRAM

